

The Mercury-Redstone Gantry.

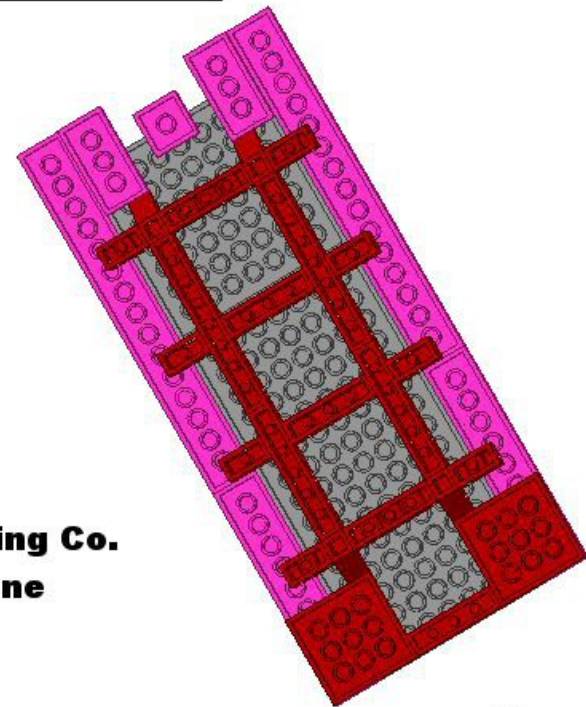

Only a few things you need to be aware of if you build the gantry.

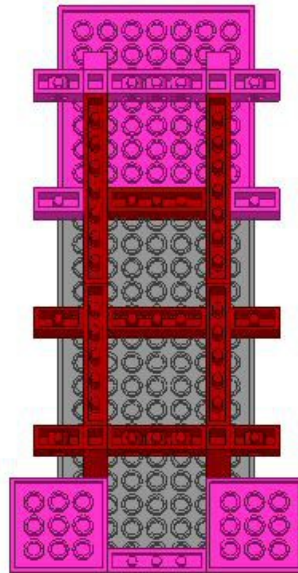
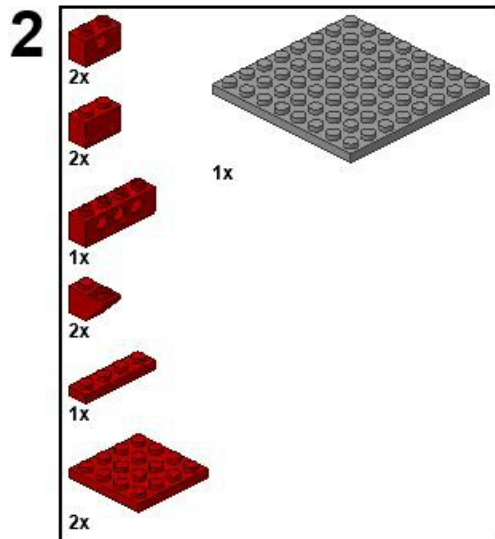
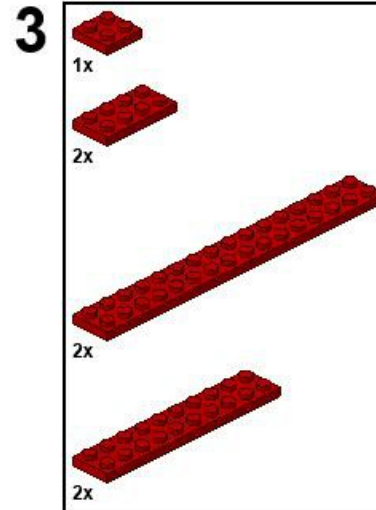
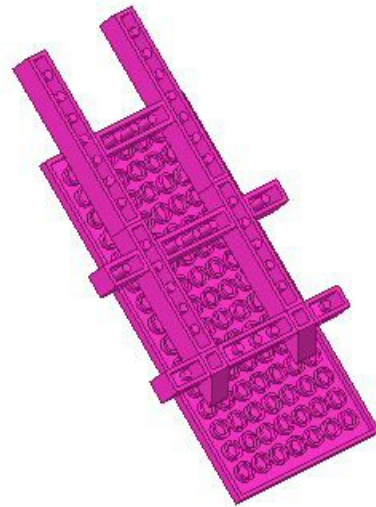
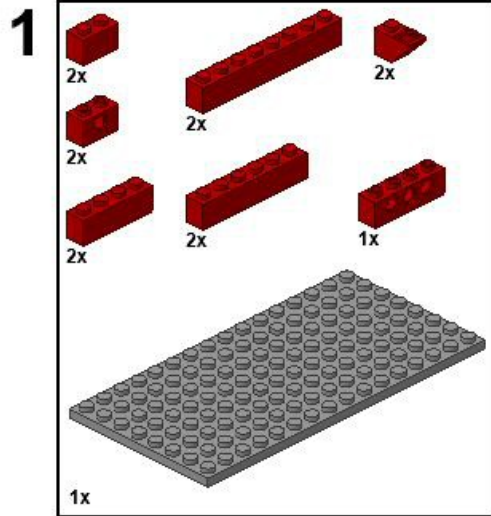

1. It is important that the fixed sections of each platform are aligned centrally on the axles between the A-Frame connections . The Connections also need to be evenly spaced from either side of the fixed platform. It is recommended that the attachment points are checked against the pins on the A-frame and adjusted before being snapped into position.
2. Do the above settings for platforms the two middle platforms before they are joined together. Once joined this gives you a four point connection to the A-Frame which stabilises the frame and stops any sideways movement. By folding the frame down you can check your alignment as the rear of the fixed platforms goes into the channel on the base of the gantry.
3. The studs on the back row of the platform goes under the 'gliding groove' (Lego's description in LDD) on the 2x8 piece on the fixed part of the platform, slide the platforms all the way in - they will stop in at the mid point. Make up the end stops from the 1x2 roof tiles and 1x2 angular plates and attach them to the ends of the fixed platform's 1x12 plates (the sub-sub assemblies when you built the fixed platforms). On the middle section you need to guide the end stops over the technic connectors to the A-frame before they can be clicked into place.

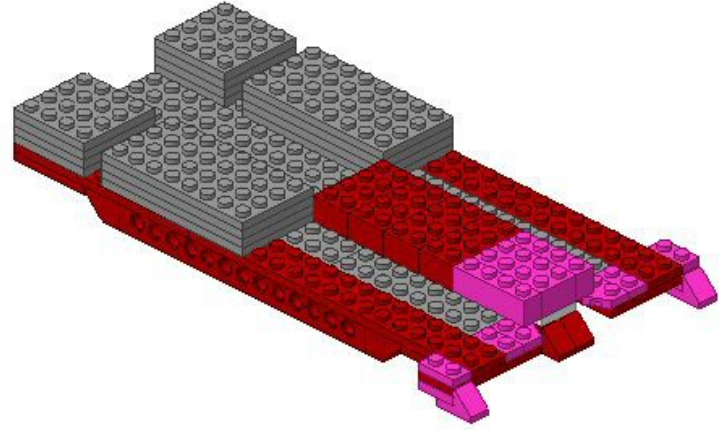
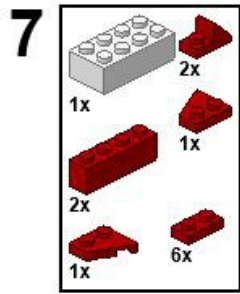
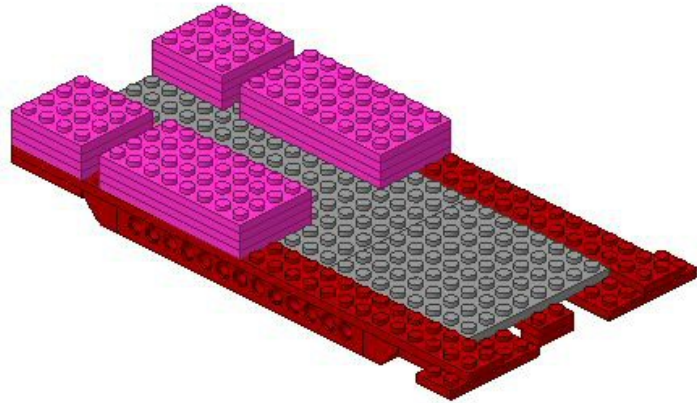
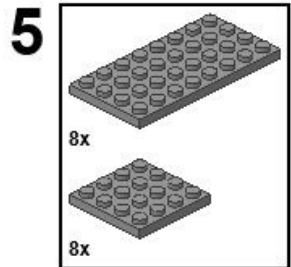
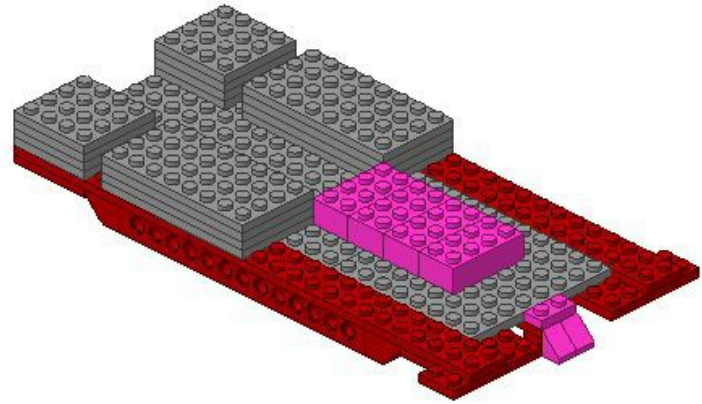
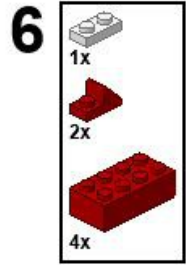
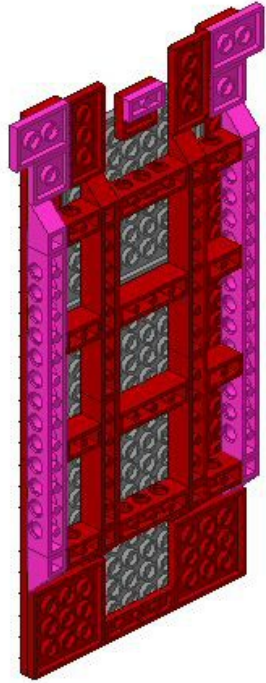
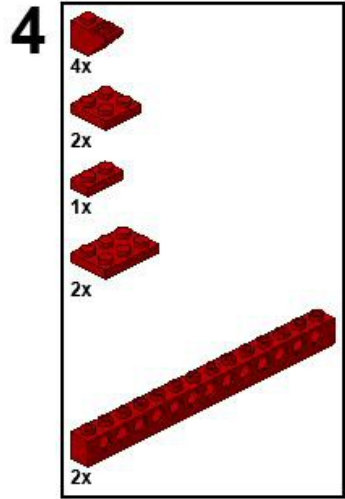

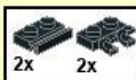
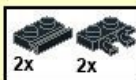
**Noble Engineering Co.
Mercury-Redstone
Gantry
by
Eiffleman (C)2019**

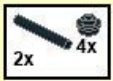
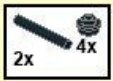

1  2x  

2  2x  

make 4

8  4x

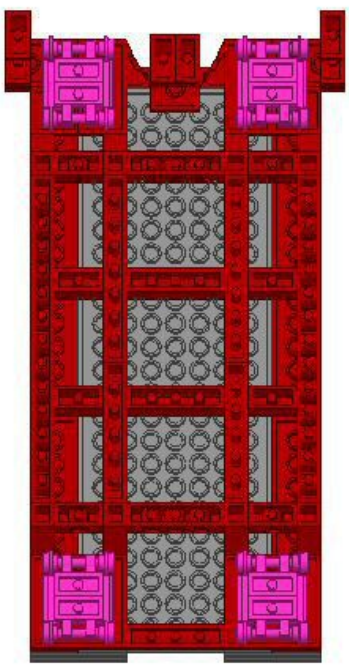

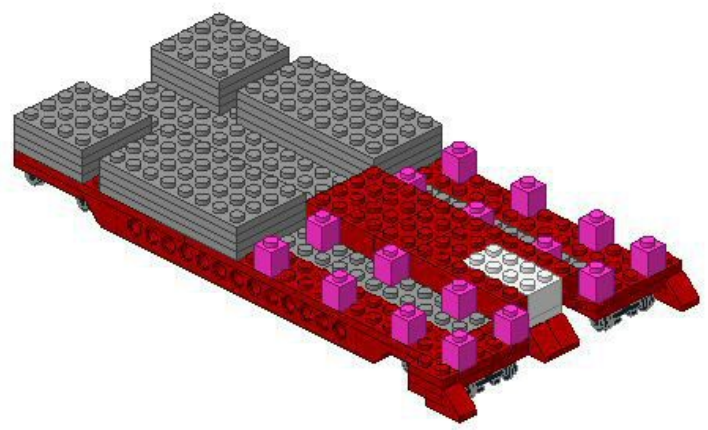

9  16x



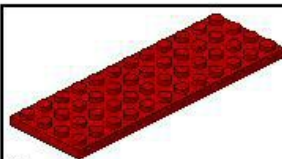

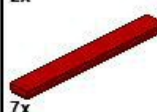
10

 2x

 7x

 1x

 10x

 1x

 2x

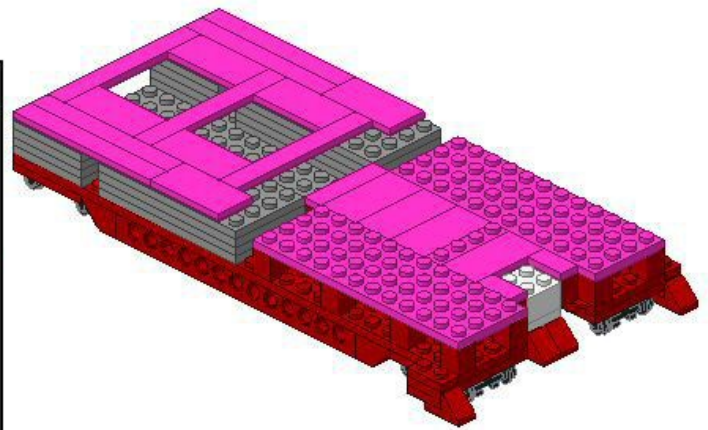



11

 3x

 2x

 1x

 2x

 2x

 2x

 2x

 4x

 5x

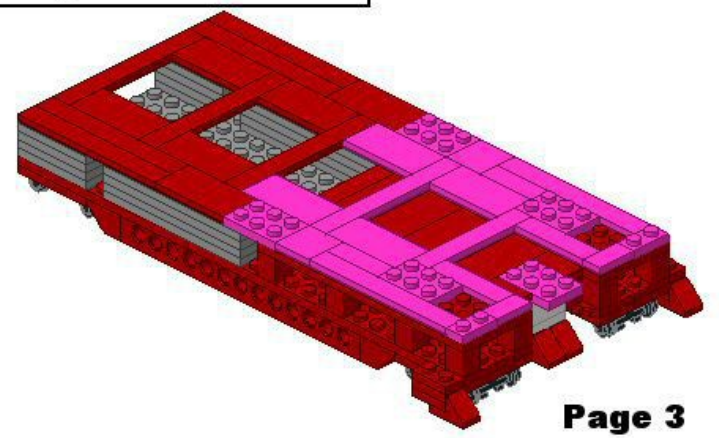

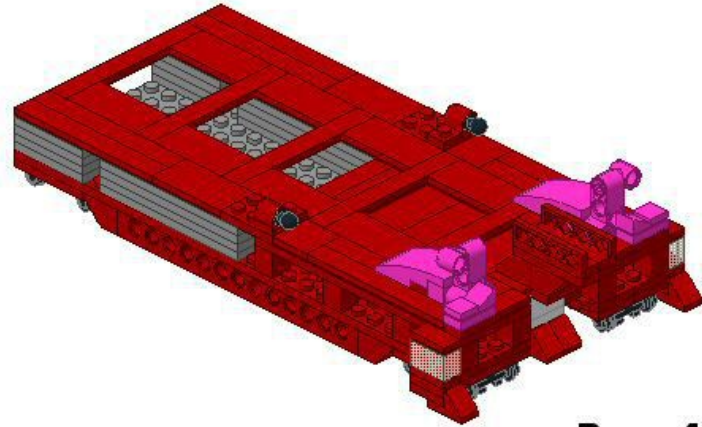
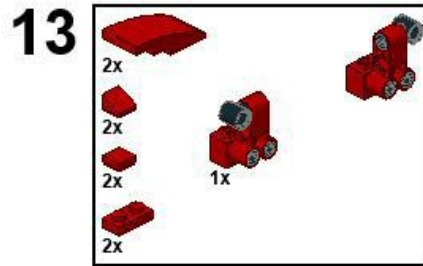
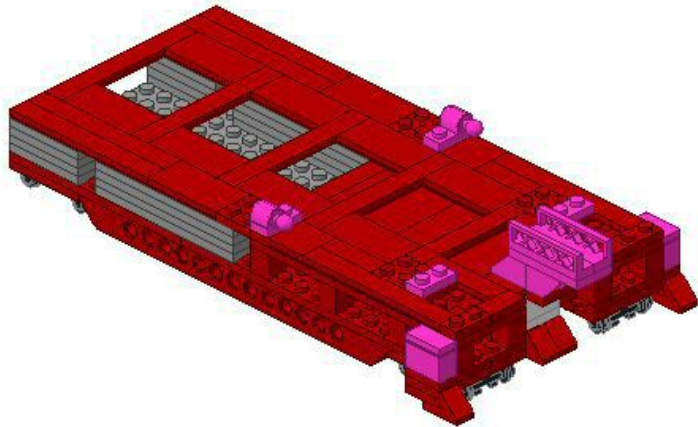
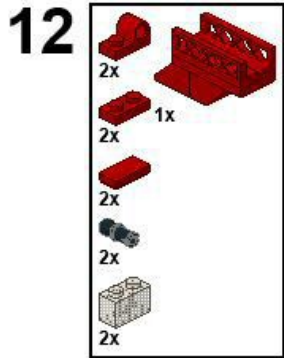
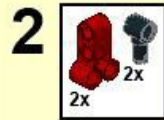
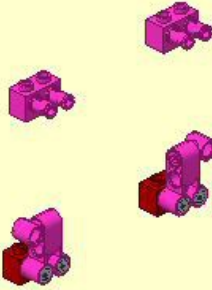
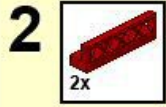
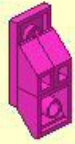
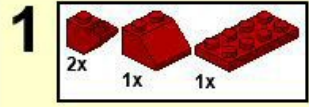

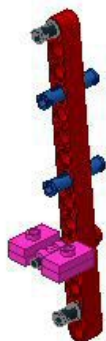
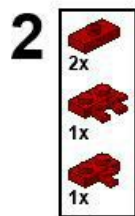
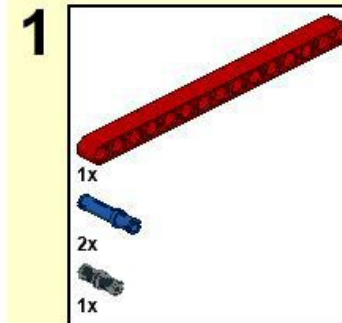
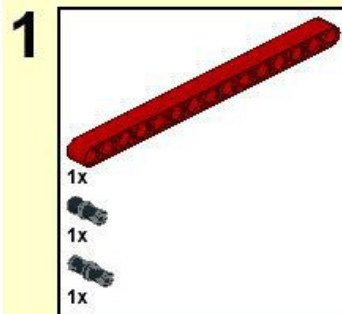
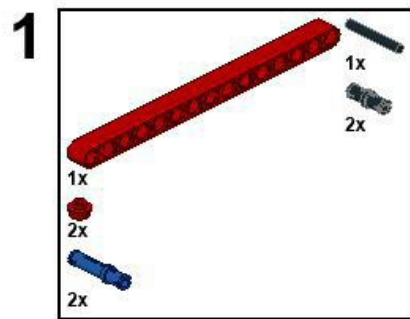

Make 2 A-Frame Arms

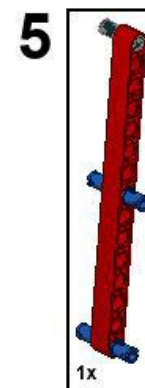
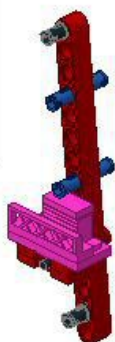
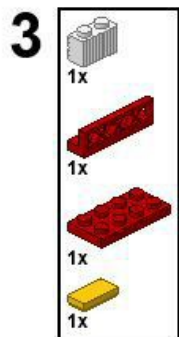

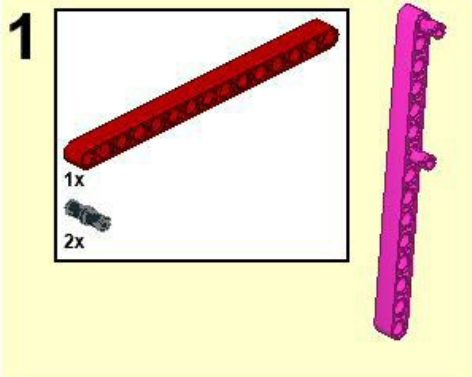

Make 2 A-Frame Arms

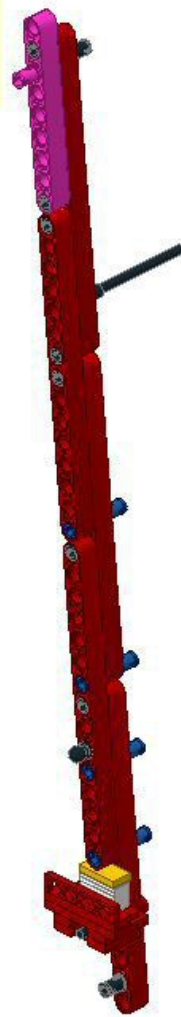
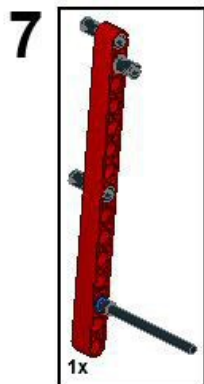
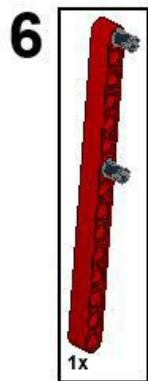
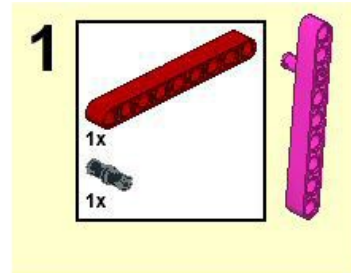
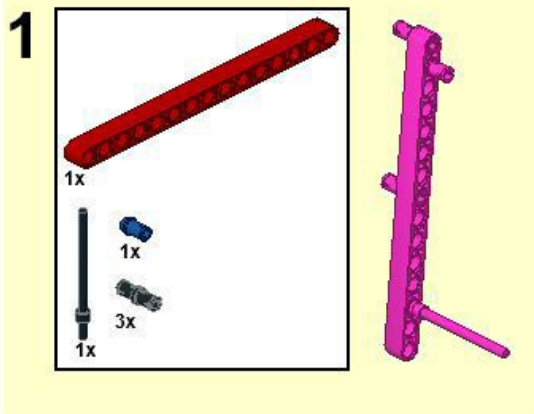

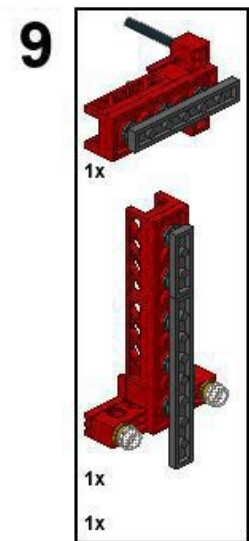
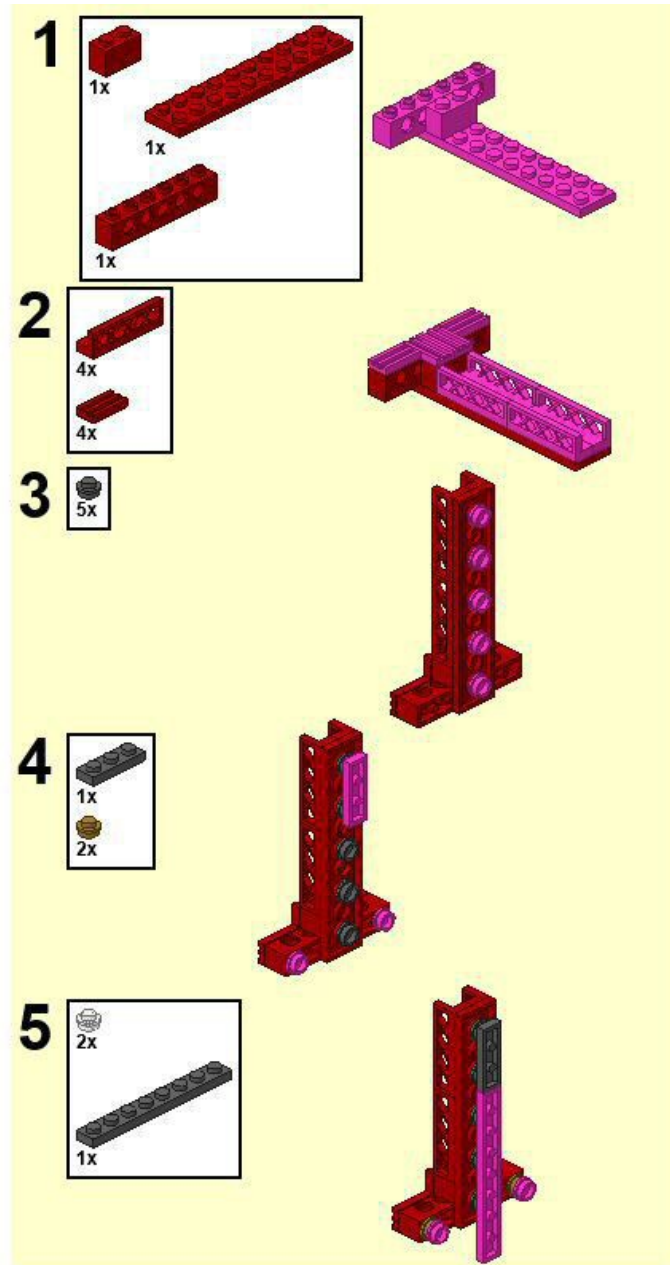
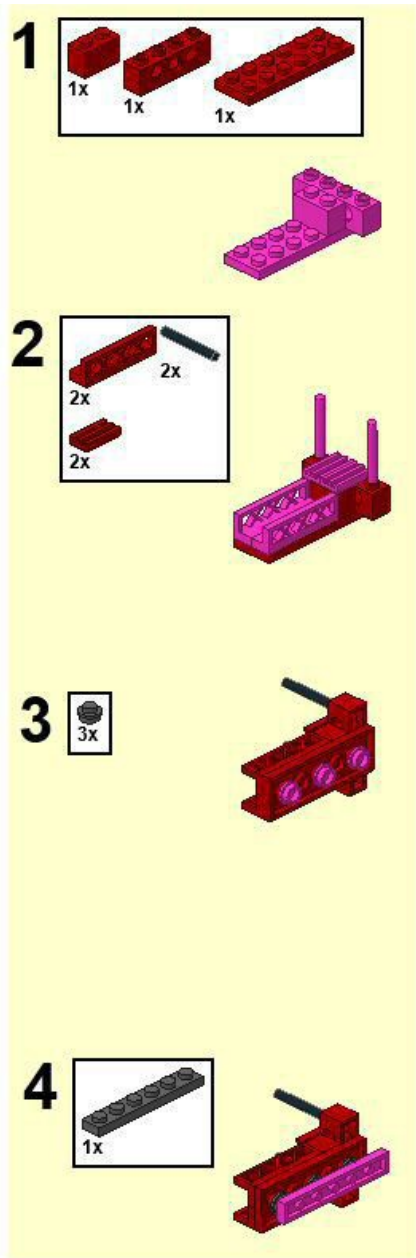

1

1x
1x
1x

2

1x
1x
1x

3

1x
1x
1x

Make 2

10

2x

**Adjust the two short platforms
so they are level with the base**

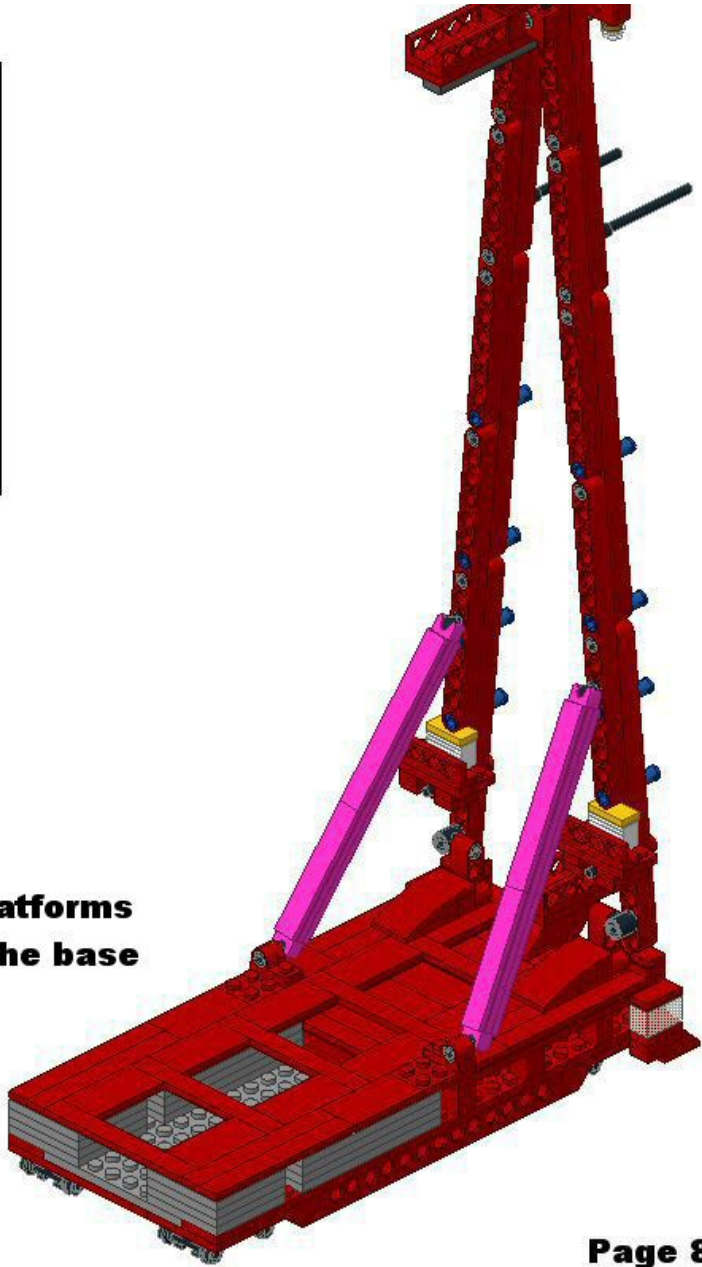

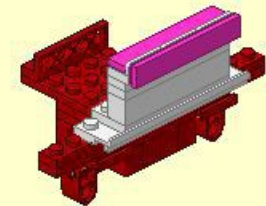
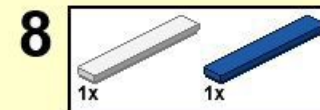
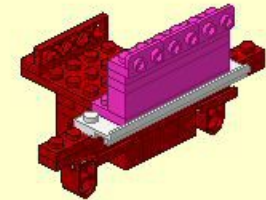
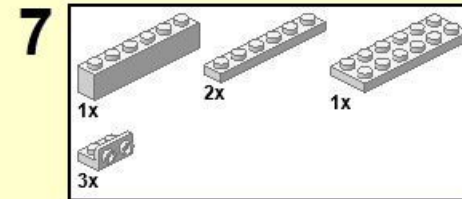
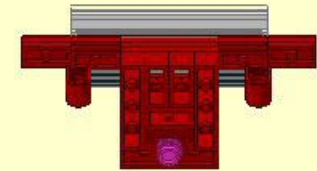
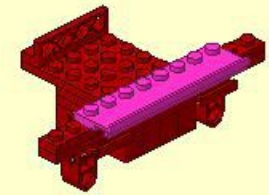
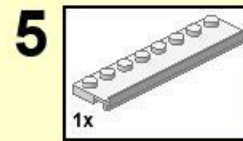
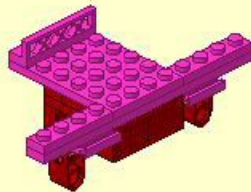
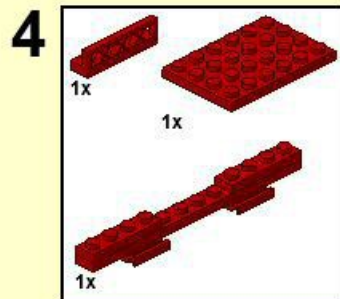
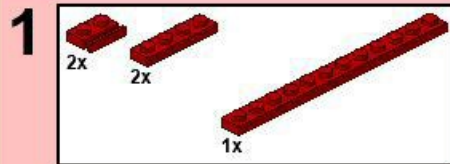
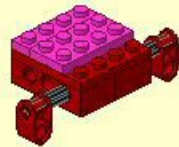
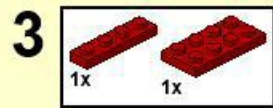
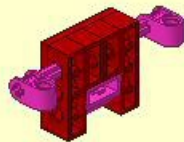
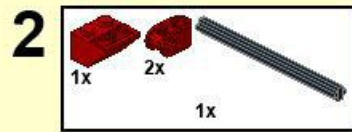
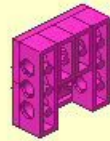
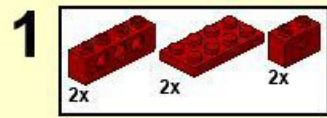

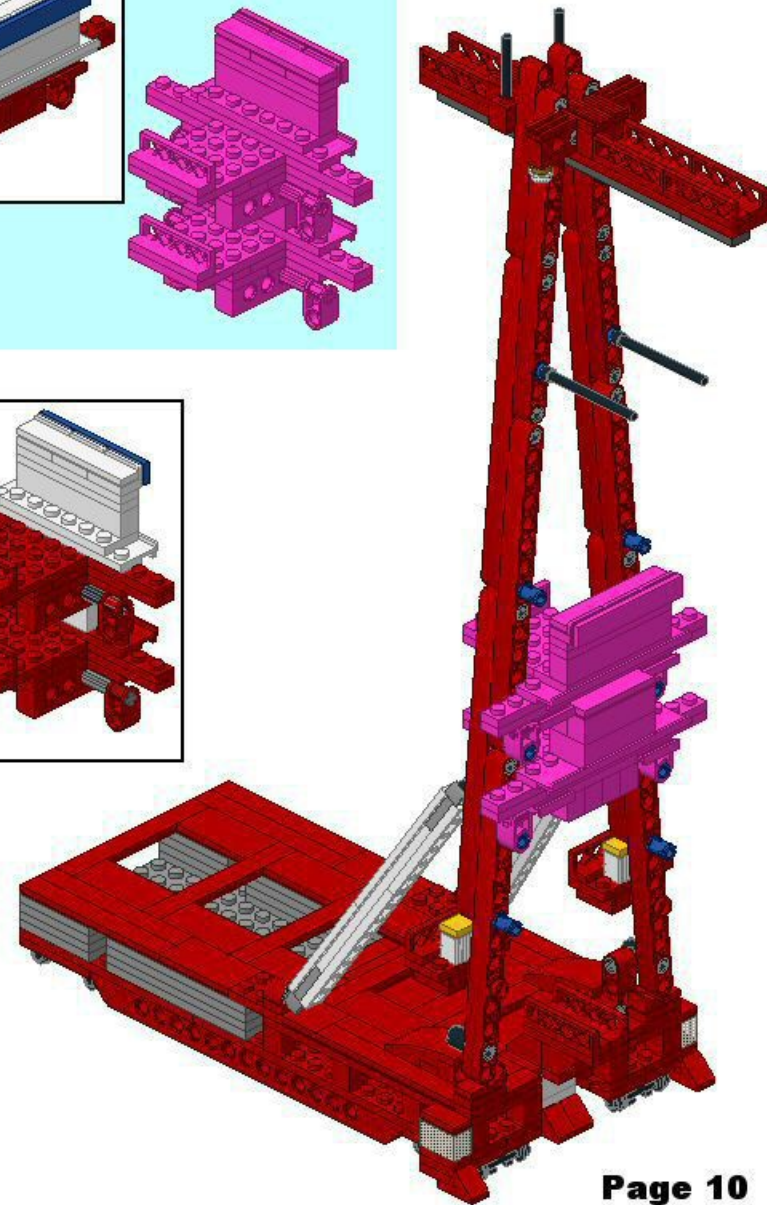
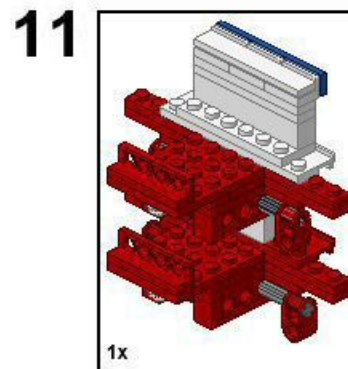
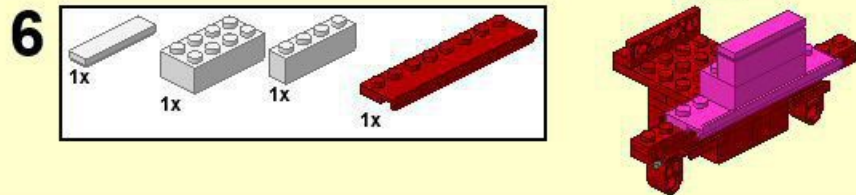
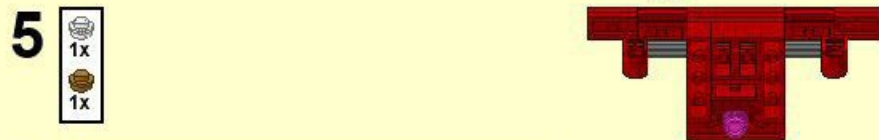
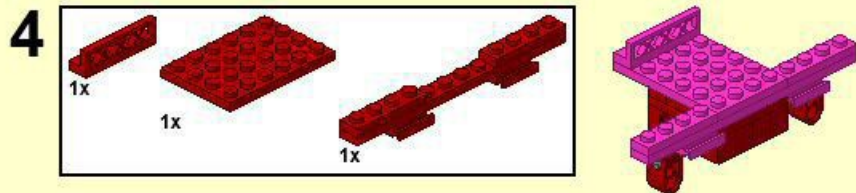
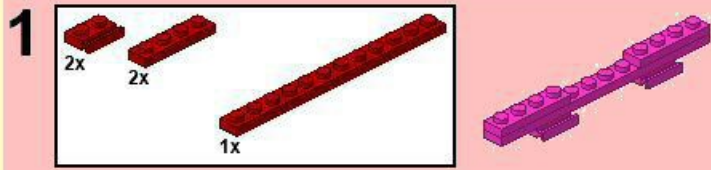
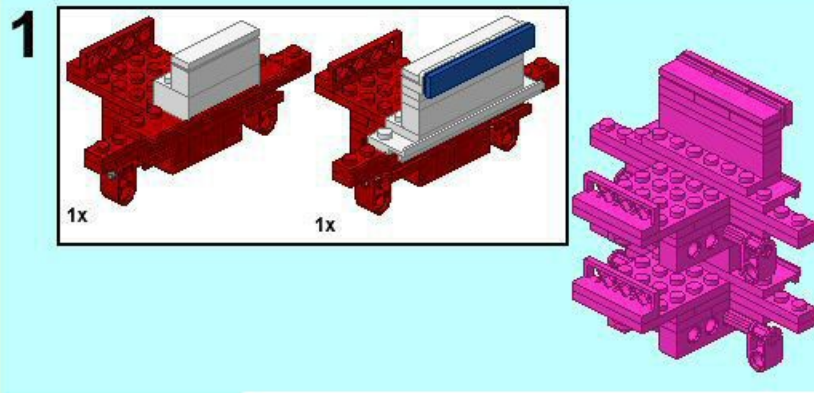
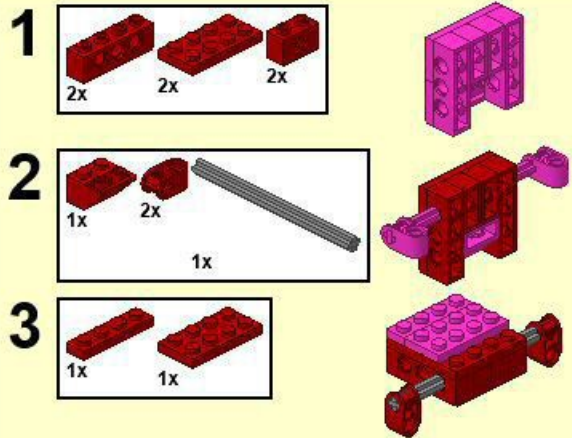

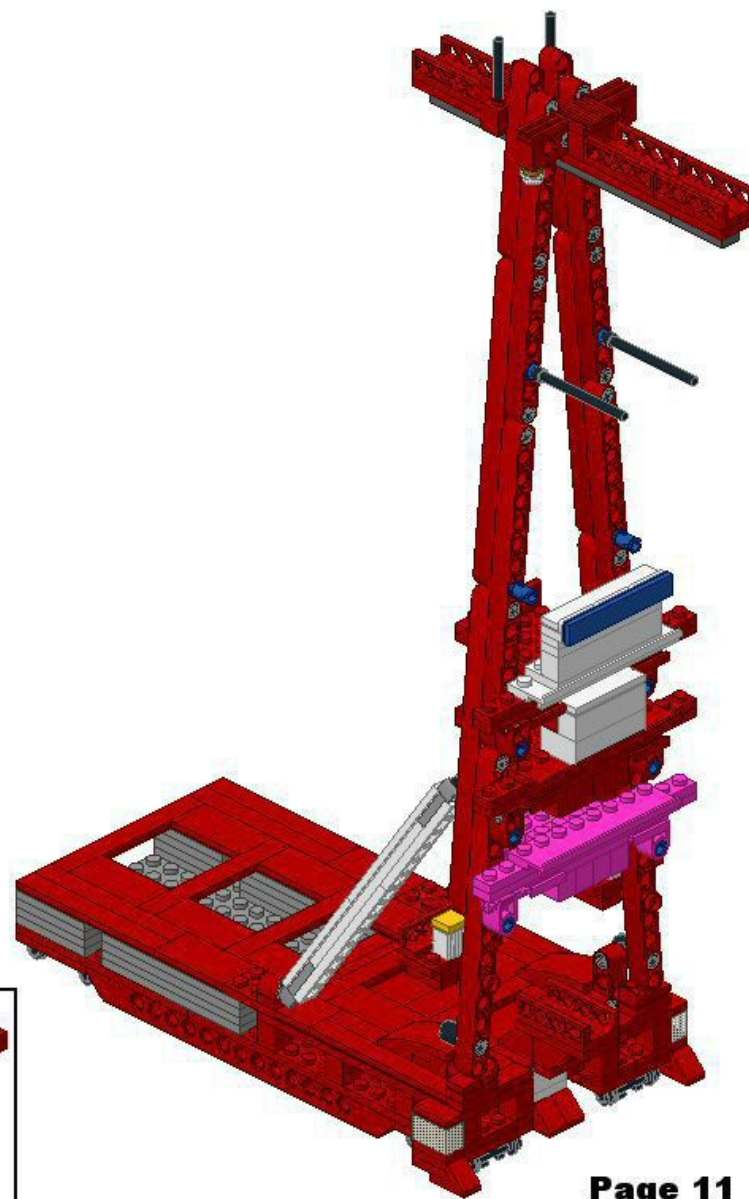
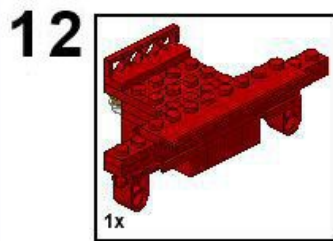
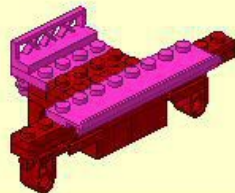
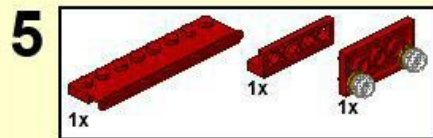
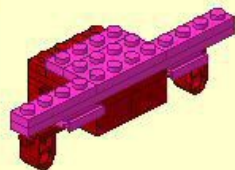
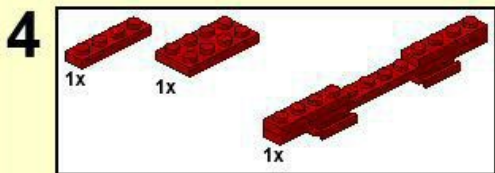
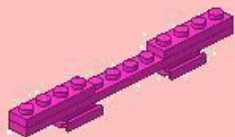
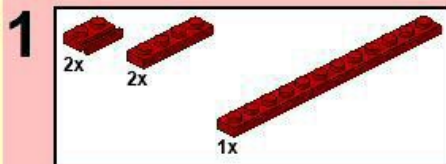
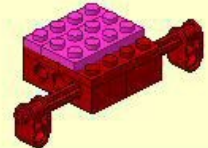
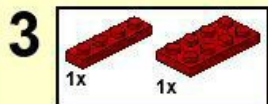
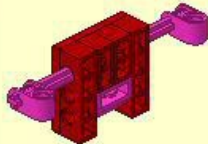
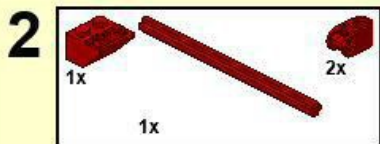
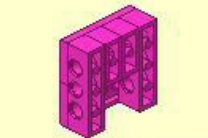
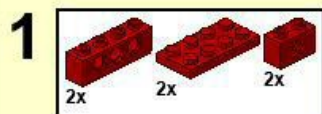

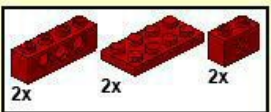
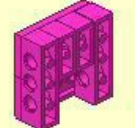

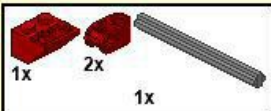
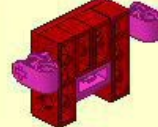

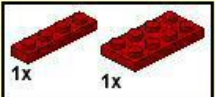
1  

2  

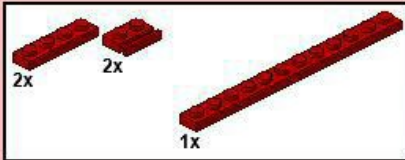
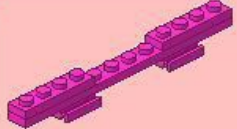
3  

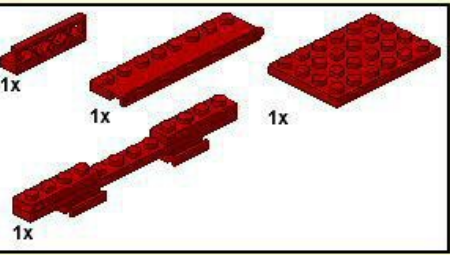
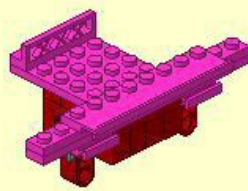
1  

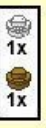
4  

5  

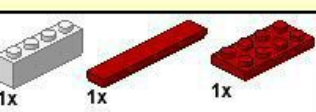
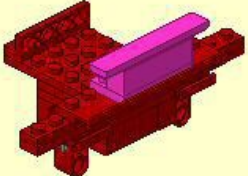
6  

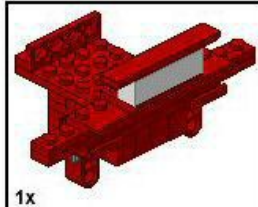
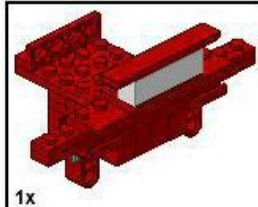
13  

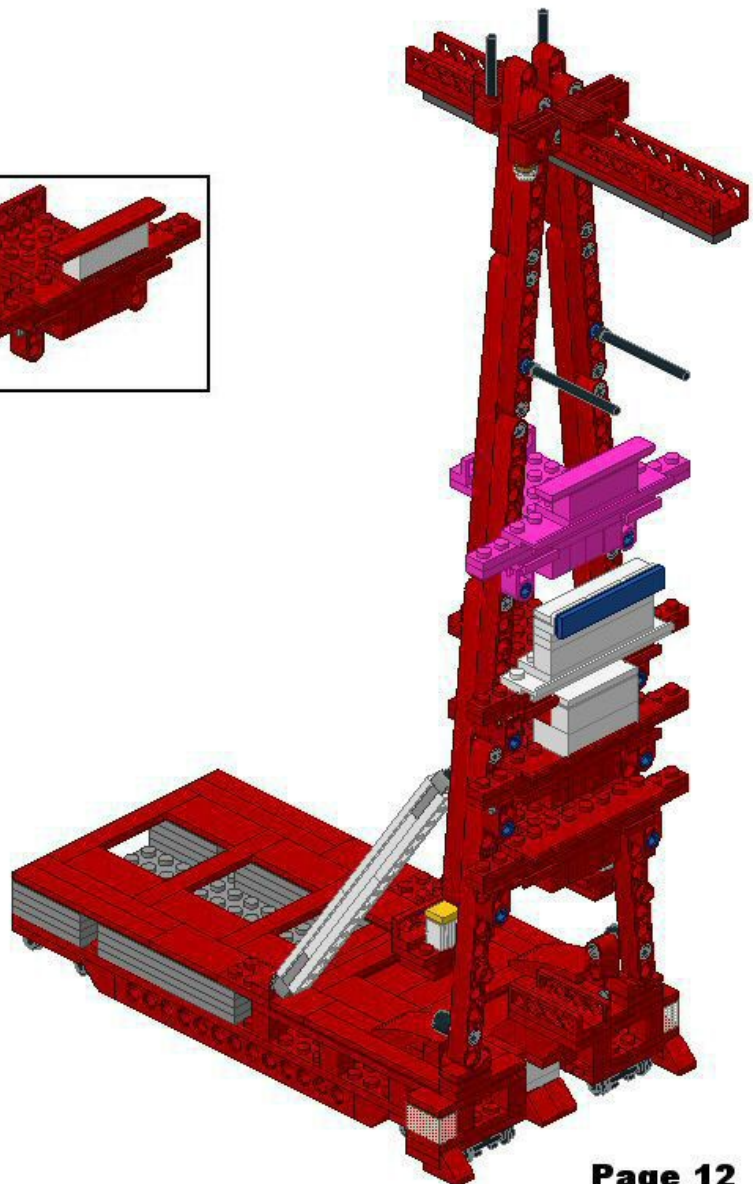

1

2

3

4

5

14

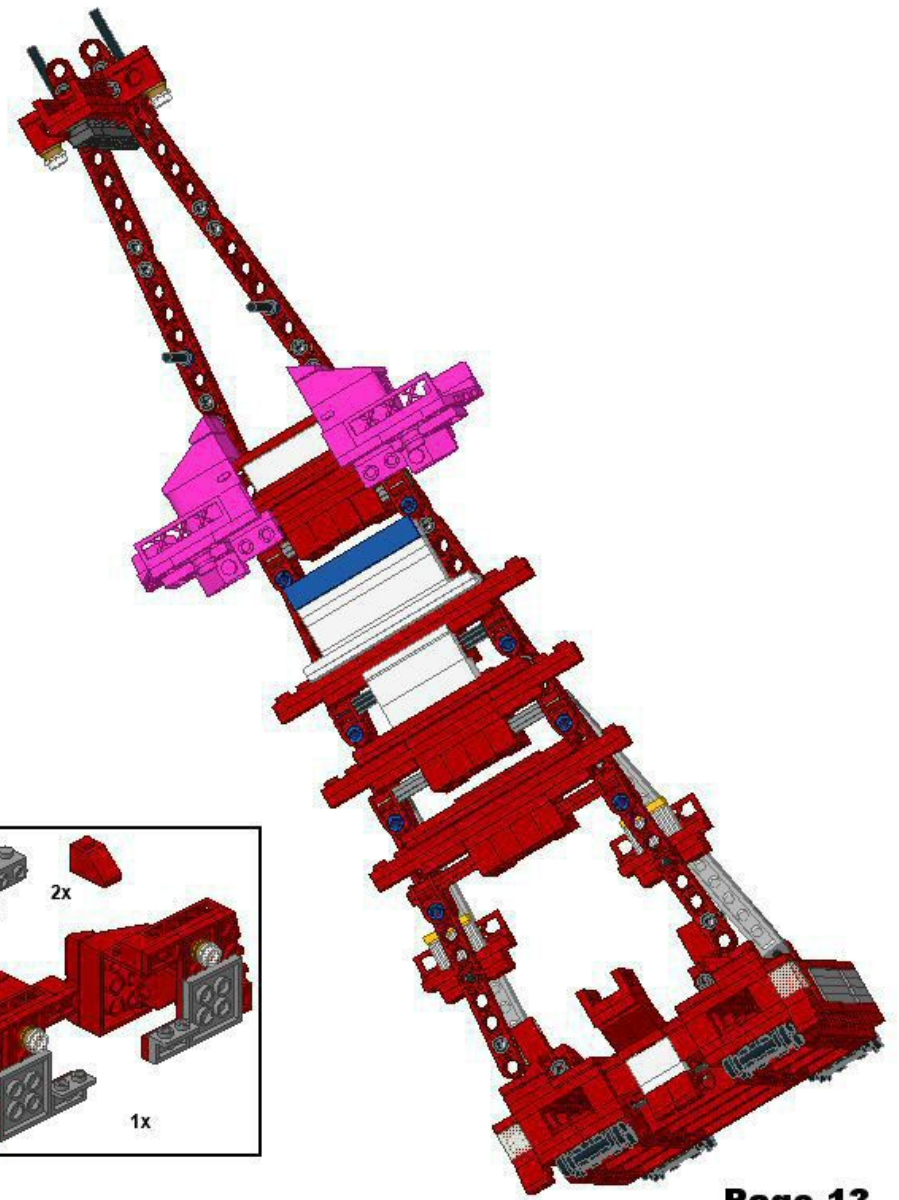

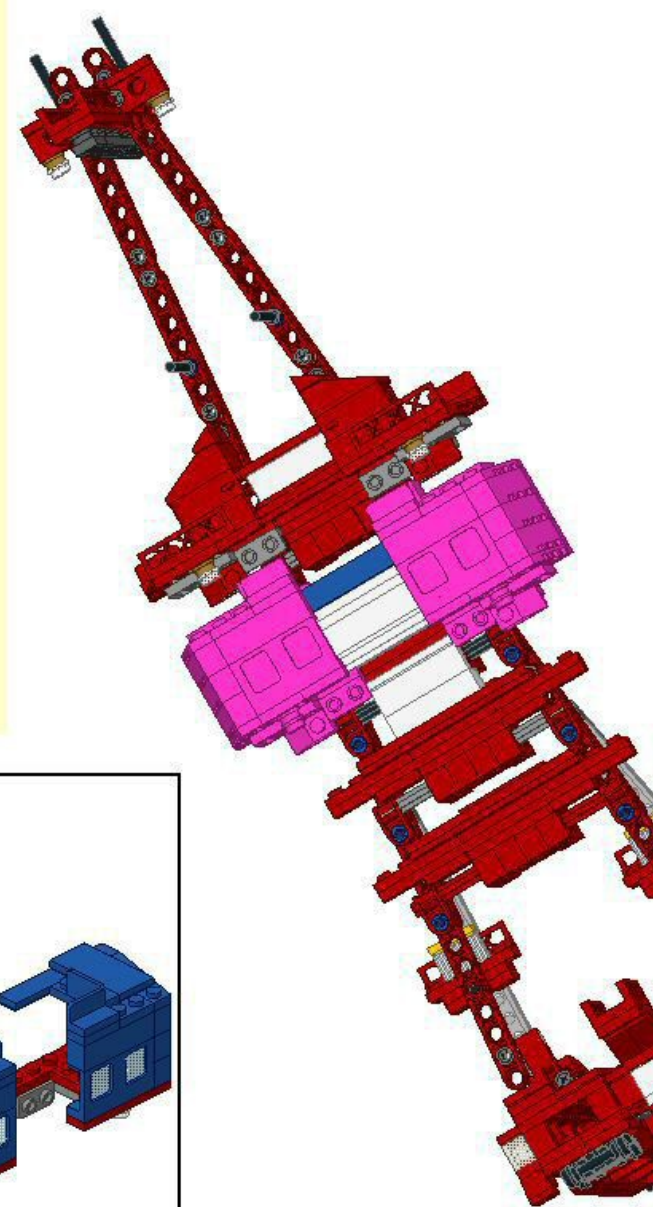
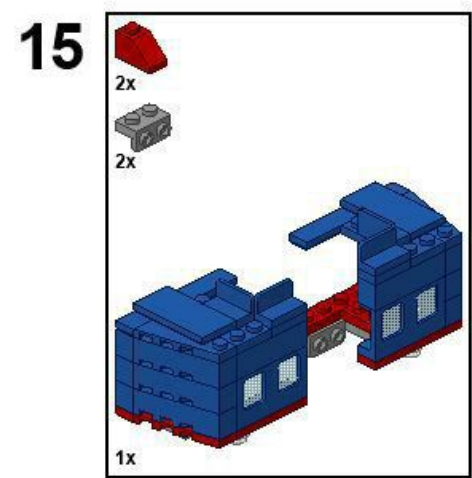
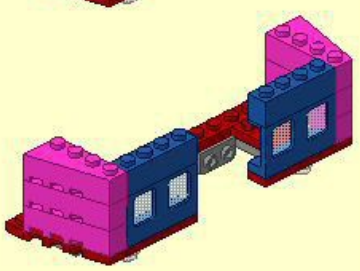
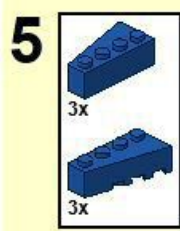
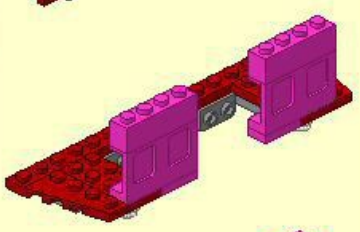
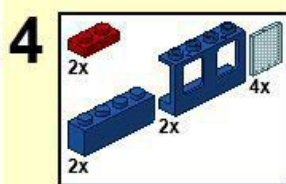
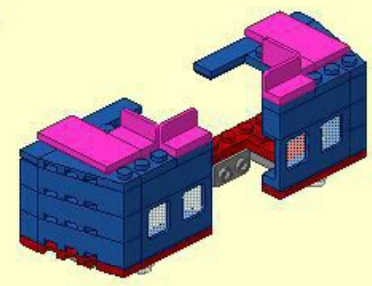
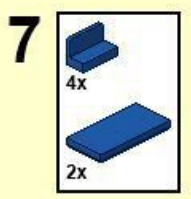
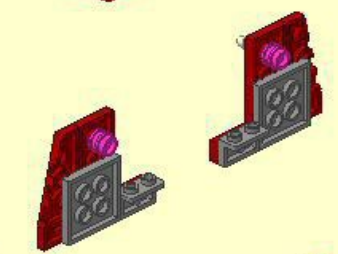
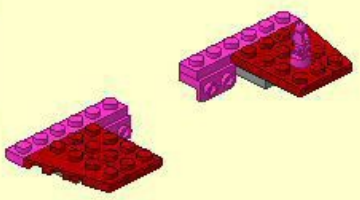
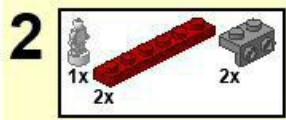
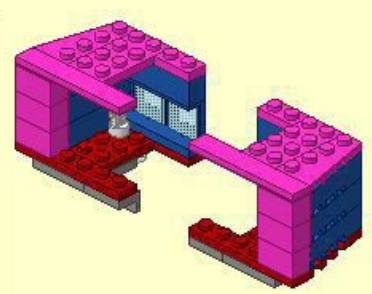
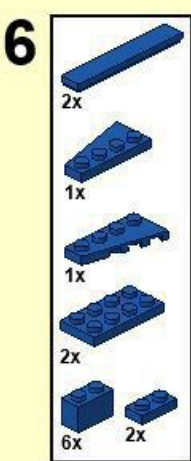
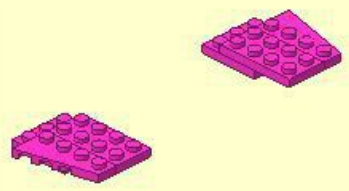
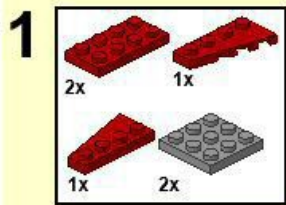

1

2

3

4

5

6

16

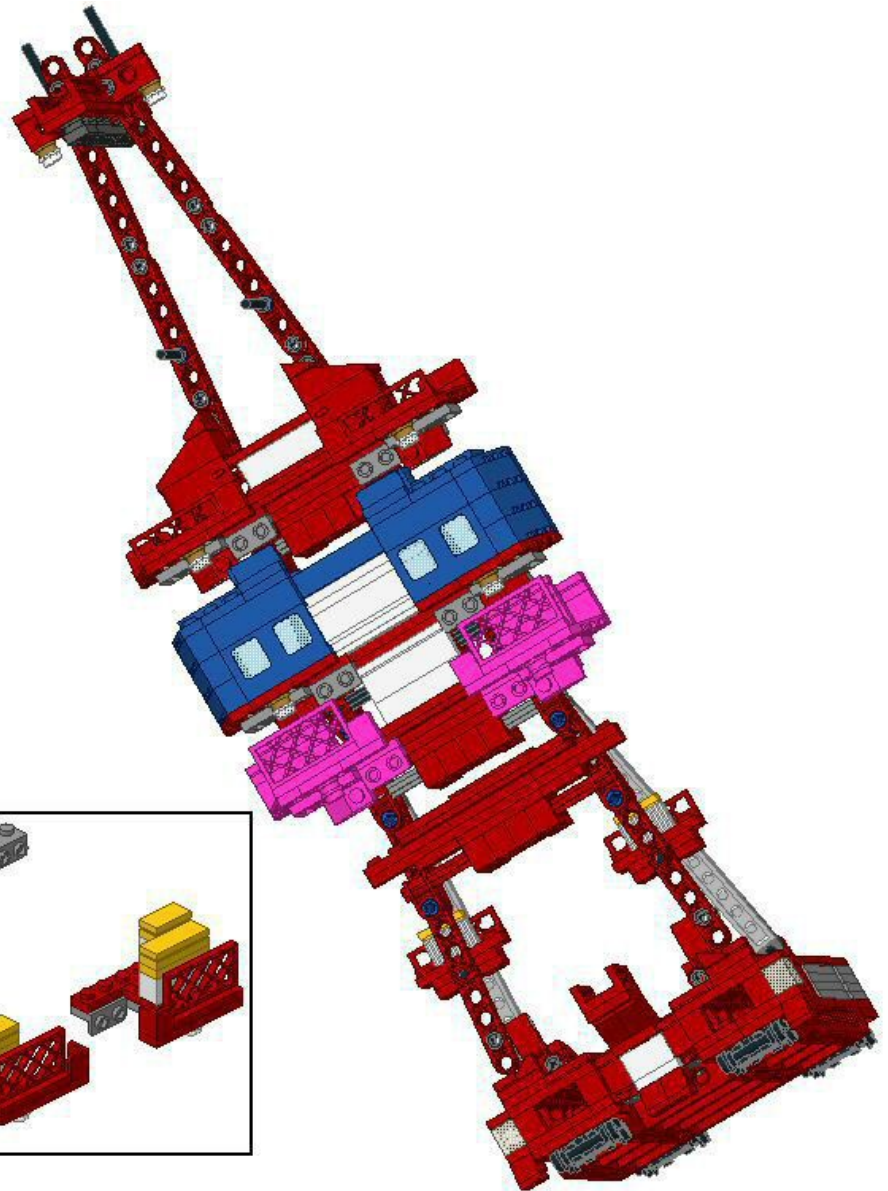

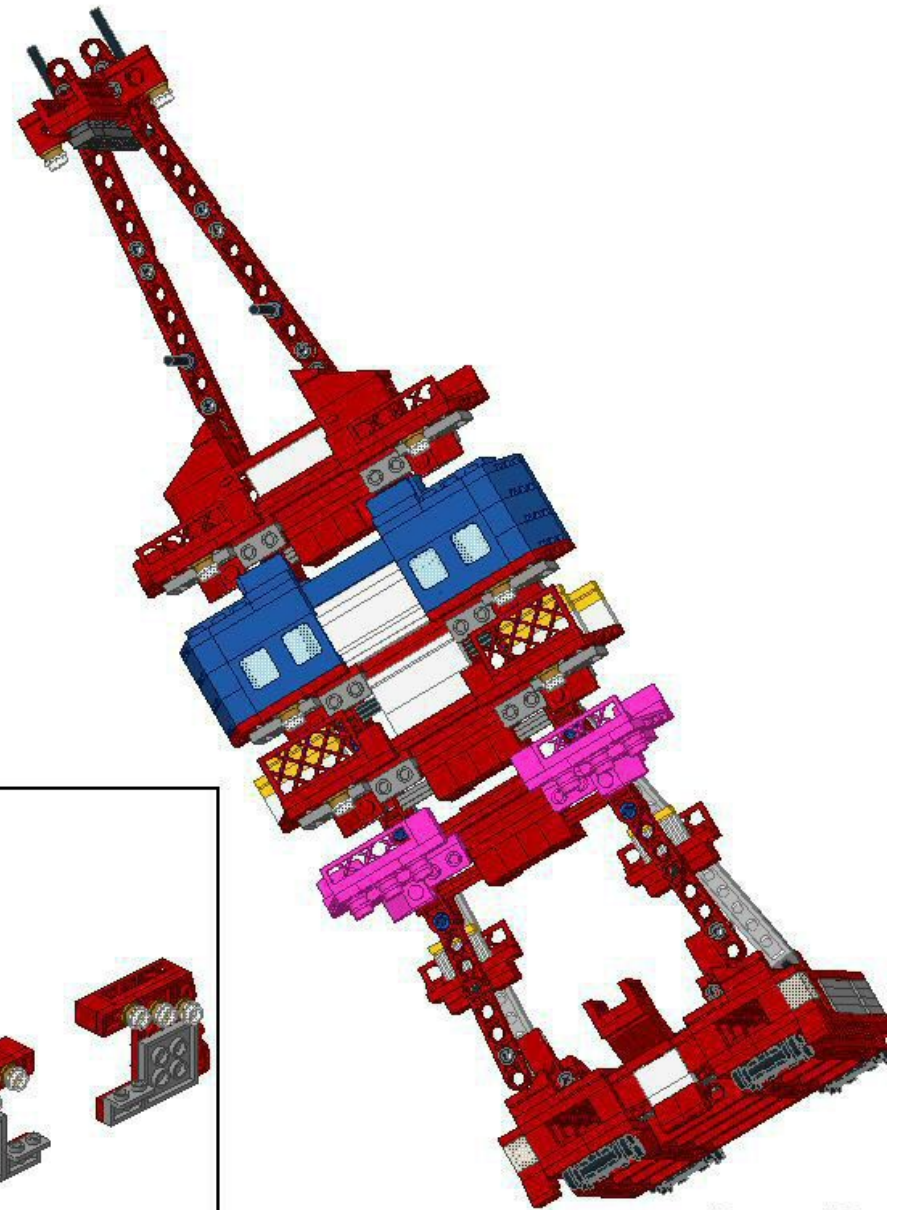
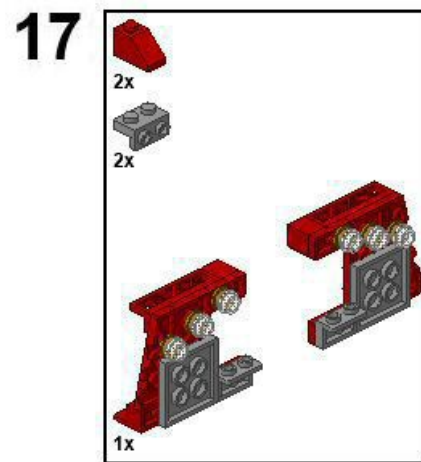
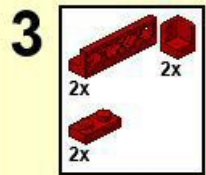
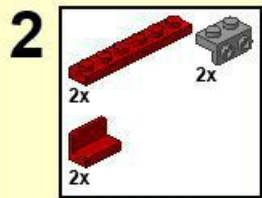
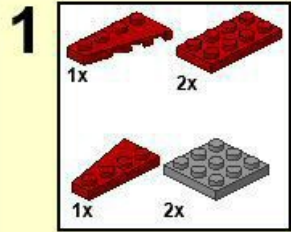

- 1x 3009
- 2x 2877
- 2x 3001
- 1x *90398
- 1x 3795
- 3x 99780
- 2x 3622
- 2x 3010
- 1x 30586
- 1x 2431
- 4x 3666
- 2x 3460

- 2x 4162
- 1x 3023
- 3x 6636
- 2x 3004
- 2x 4477
- 11x 3701
- 4x 3660
- 2x 32018
- 4x 3010
- 2x 3008
- 2x 3297

- 15x 3710
- 3x 2431
- 4x 92946
- 2x 3009
- 8x 32028
- 4x 85861
- 4x 3001
- 1x 24299
- 4x 3794
- 2x 63864
- 2x 60470
- 2x 3068
- 2x 32557
- 2x 24307
- 8x 6536

- 2x 6636
- 14x 87079
- 2x 11458
- 2x 4283
- 6x 6231
- 1x 3737
- 1x 3894
- 1x 3795
- 6x 3069
- 4x 60479

- 10x 32278
- 2x 3070
- 2x 11476
- 2x 3185
- 28x 3020
- 2x 3821
- 3x 30586
- 8x 32064
- 2x 3029
- 12x 3665
- 2x 3822
- 16x 3005

***White Astronaut or Silver Trophy Figure**

- 7x **3021**
- 8x **3666**
- 2x **93606**
- 2x **50746**
- 1x **3039**
- 18x **3185**
- 3x **3022**
- 4x **85984**
- 10x **4162**
- 4x **32000**
- 3x **3832**
- 2x **3031**
- 4x **41769**
- 6x **3004**

- 4x **3700**
- 8x **3040**
- 21x **3023**
- 6x **2412**
- 4x **4865**
- 2x **40490**
- 4x **41770**
- 3x **3032**
- 2x **61345**
- 2x **4274**
- 6x **3004**
- 3x **41767**
- 2x **3020**
- 3x **6636**

- 2x **87079**
- 3x **41768**
- 2x **3010**
- 1x **41769**
- 2x **3023**
- 4x **4865**
- 8x **6558**
- 1x **41770**
- 2x **63864**
- 4x **3623**
- 4x **3069**
- 2x **3023**
- 8x **32028**
- 16x **85861**
- 2x **15100**
- 4x **6628**

- 8x **60470**
- 24x **2780**
- 2x **63965**
- 1x **3707**
- 12x **87994**
- 19x **6141**
- 4x **60601**
- 2x **3004**
- 8x **3035**
- 1x **92438**

- 8x **11212**
- 16x **99781**
- 4x **14418**
- 8x **3031**
- 1x **41539**
- 1x **60485**
- 1x **44294**
- 8x **6141**
- 1x **3666**
- 1x **3460**
- 19x **6141**